

Torque Settings



Suzuki M16A

Head Bolt Part #: 30076088

Torque Setting:

- Stage 1: Bolts 1 to 10 20 Nm
- Stage 2: Bolts 1 to 10 40 Nm
- Stage 3: Bolts 1 to 10 +60 Degrees
- Stage 4: Bolts 1 to 10 +60 Degrees
- Stage 5: Bolt "A" 25 Nm

Torque Sequence:

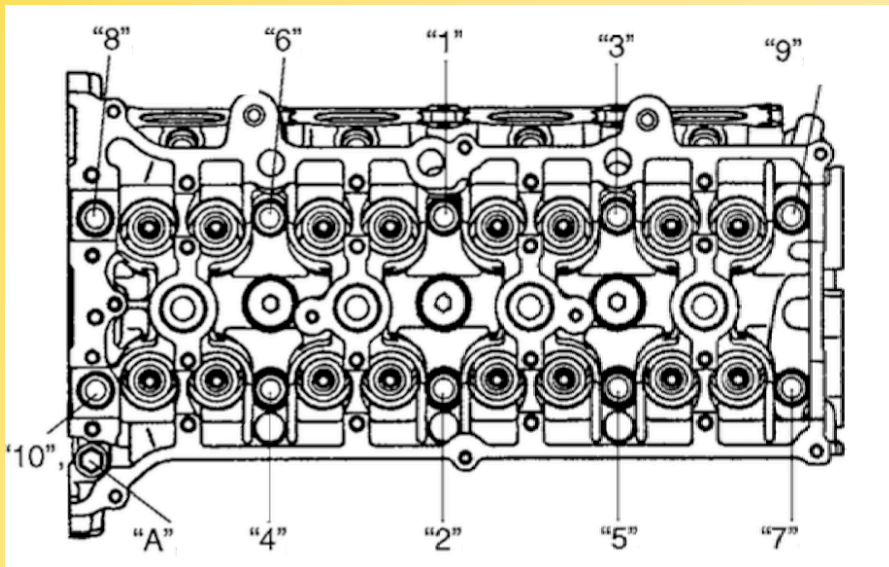

Notes:

All Threads, Heads & Washers must be lightly oiled.

Use an old head bolt with a groove cut down the thread to clean the threads in the block.