

# Torque Settings



## Mitsubishi 4P10

Head Bolt Part # 30046045

### Torque Setting:

**Stage 1:** Bolts 1 to 6 130 Nm

**Stage 2:** Bolts 7 to 10 65 Nm

**Stage 3:** Bolts 1 to 6 +90 Degrees

**Stage 4:** Bolts 7 to 10 +90 Degrees

**Stage 5:** Bolts 1 to 6 +90 Degrees

**Stage 6:** Bolts 7 to 10 +60 Degrees

**Stage 7:** Bolts 'A' 25 Nm

### Torque Sequence:

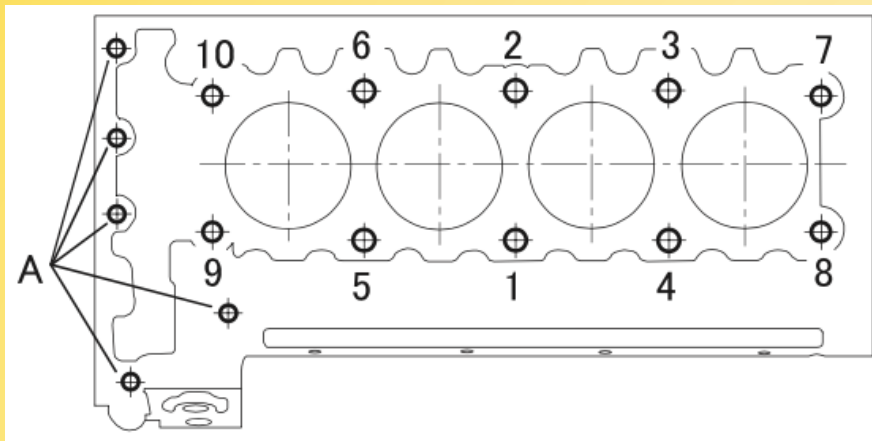

### Notes:

All Threads, Heads & Washers must be lightly oiled.

Use an old head bolt with a groove cut down the thread to clean the threads in the block.